



En

Triana

Ramón Úbeda  
& Otto Canalda

**Triana** is a floor lamp in the manner of those made in the past. With three feet in this case. Elegant and noble. With a sculptural housing and a fine handmade chintz lampshade. Its singularity is that it comes in three shade sizes for the same base, shades that can be changed around and give it three different personalities according to their size: small, medium or large. All are just as good in the living room of the most select houses or the hall of the most elegant hotel. Designed by **Ramón Úbeda** and **Otto Canalda**, it came onto the market in 2008 with a black lacquered foot, stylised like a stiletto heel. It is now available in three new versions that triple its possibilities: In bright white colour, luminous yellow –also for the shade– which will not go unnoticed, and a quiet version in natural wood finish to satisfy Nordic taste.



**Triana**  
**Yellow**





Wood



Yellow



Black

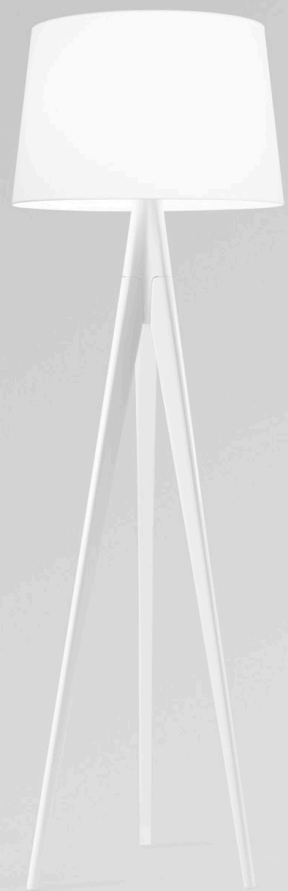

White



**Triana**  
**White**



Pe



Me

Triana  
Wood











Triana  
Black







**Hospes Maricel & Spa Hotel, Mallorca**



**Catalonia Passeig de Gràcia Hotel, Barcelona**



**Das Stue Hotel, Berlin**



**Triana Pe, Me and Gr**





## Ibai Acevedo (Barcelona, 1984)

was a graphic designer before he took up photography. Self-taught, he learnt the trade of photography by himself and in freedom. And that's how he likes to work, either for pleasure or by commission, as in this case, composing images with strong colours combining reality and fiction. Or vice versa. In his large repertory of dreams, he creates atmospheres or portraits in his own style, which he himself defines as effectist, because what is important is to transmit. And he does.



**Triana**  
**Technical information**

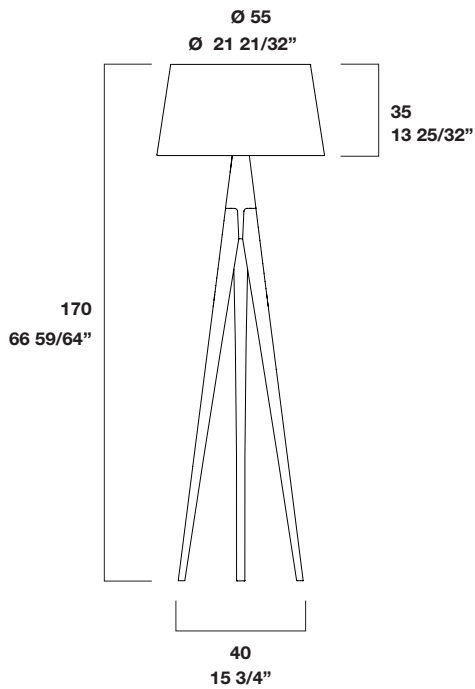

**Triana Pe**

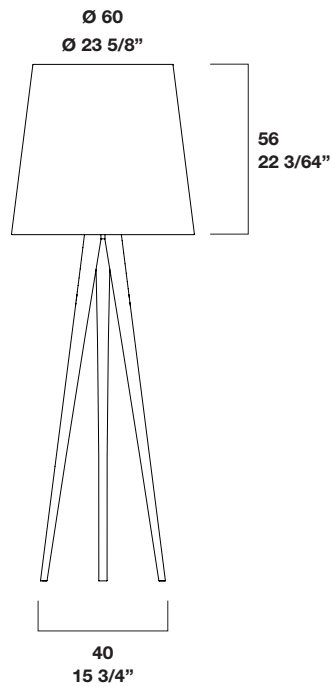

**Triana Me**

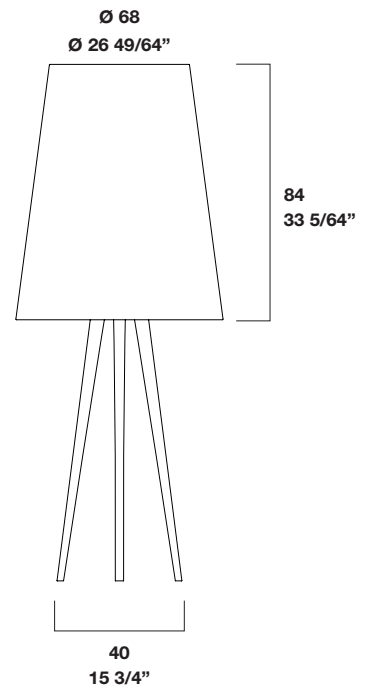

**Triana Gr**

A floor luminaire with a structure that enables any of three shade sizes to be fitted, making it highly versatile: an ambient light with two large shade sizes or a smaller size for reading. It blends perfectly into residential atmospheres as well as contract interiors.

Design by Ramón Úbeda  
& Otto Canalda

Shade in white, black and yellow chintz fabric. A standing lamp in natural wood or injected polyurethane, finished in black and white piano lacquer or painted satin yellow.

Dimensions cm / inches

**metalarte**<sup>TM</sup>  
lightstyle

GRUPO LUXIONA  
Paseo de la Ribera, 115  
08420 Canovelles  
Barcelona, Spain

T +34 93 846 69 09  
F +34 93 846 57 09

metalarte@metalarte.com  
www.metalarte.com  
www.luxiona.com